



深圳市晶峰达电子科技有限公司  
东莞市琪芯电子有限公司

电话: 13798528768, 0755-29208918, FAX: 81703081  
邮箱: info@jfd-ic.com, QQ: 402431824 阿里旺旺: szjfdz  
网址: www.jfd-ic.com MSN: aleafuyzf@hotmail.com

**DL8983**

## 6 LED Flash Controller

### Features:

- CMOS technology
- The rang of operating voltage : 1.5V-5.0V DC .
- Static current < 5uA .
- Output current : current > 20mA .in VDD=3V .
- 1/2 of working period is valid .

### General Description :

This chip is designed specially , used to make the output of 6 LED lights in low voltage process. You can use this chip without external resistance. And you can also alter the flash speed with external resistance. There are many types of flash way by option..

### Application :

- Flash LED light .
- Flash siren light .
- DISCO light .
- Others .
- Light instrument .
- Christmas adornment light .
- PILI specs .

### Pin Configuration :

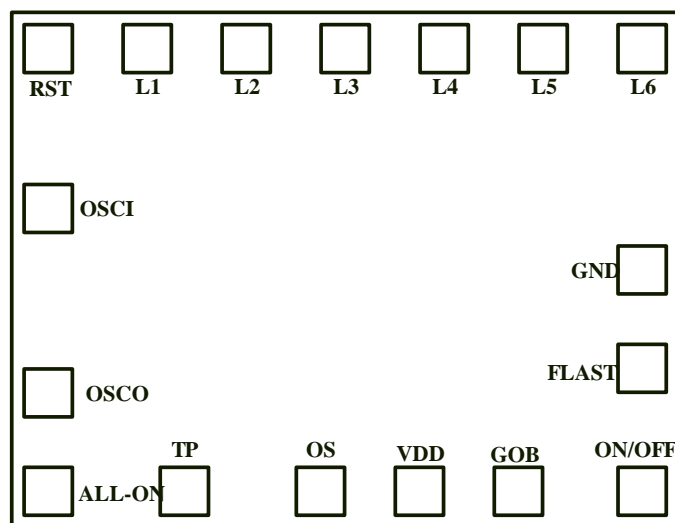



深圳市晶峰达电子科技有限公司  
东莞市琪芯电子有限公司

电话: 13798528768, 0755-29208918, FAX: 81703081  
邮箱: info@jfd-ic.com, QQ: 402431824 阿里旺旺: szjfdz  
网址: www.jfd-ic.com MSN: aleafuyzf@hotmail.com

**DL8983**

## Pin Description :

PAD	SYMBOL	FUNCTION INTRRODUCTION
1	OSCI	Oscillator input.
2	OSCO	Oscillator output.
3	ALLON	All LED lighting output by bonding VDD.
4	TP	Internal test.
5	OS	Trigger key in negative way ,LED will blink sixteen periods before stopping by triggering OS.
6	VDD	Positive power supply.
7	GOB	Blink to and fro /sequence flash .flash option(sequence flash ) , Blink to and fro by bonding VSS.
8	ON/OFF	LED blink /stop option key .
9	FLASH	All flash by bonding VDD.
10	VSS	Negative power supply .
11	L6	LED6 output.
12	L5	LED5 output.
13	L4	LED4 output.
14	L3	LED3 output.
15	L2	LED2 output.
16	L1	LED1 output.
17	RST	The control of LED amount ,LED flash from L1 to L5 by bonding L5 and flash from L1 to L4 by bonding L4, etc.

## Application Circuit :

Example 1: Apply power supply as ON/OFF key ,not bonding external resistance.

Example 2: Apply power supply as ON/OFF key, bonding external Resistance.

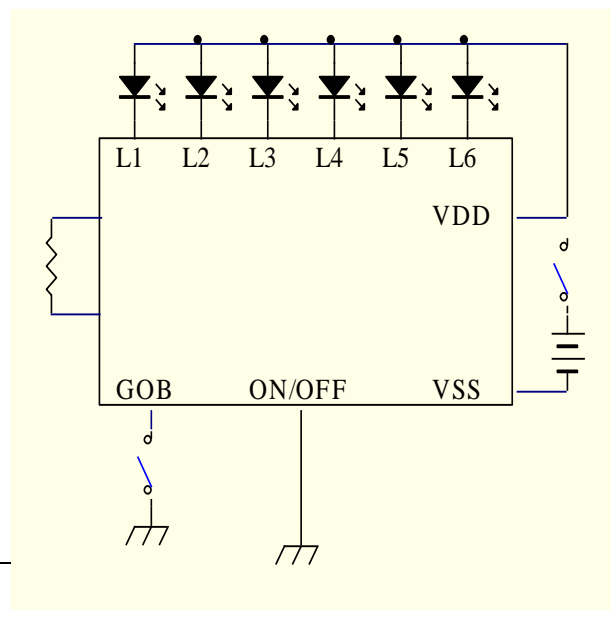
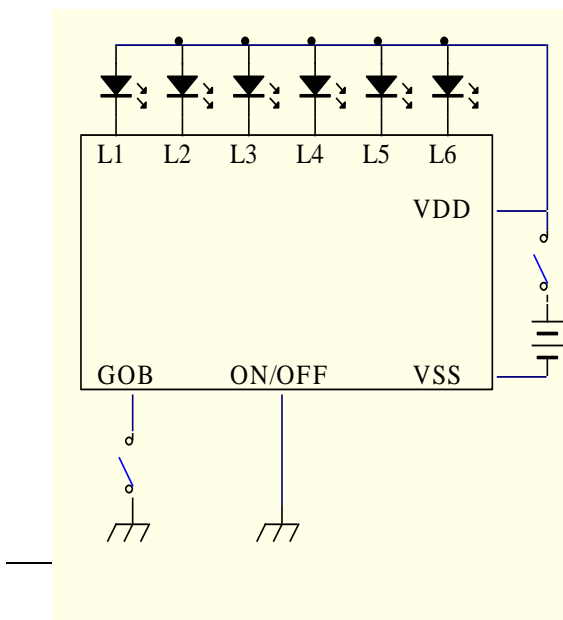



深圳市晶峰达电子科技有限公司  
东莞市琪芯电子有限公司

电话: 13798528768, 0755-29208918, FAX: 81703081  
邮箱: info@jfd-ic.com, QQ: 402431824 阿里旺旺: szjfdz  
网址: www.jfd-ic.com MSN: aleafuyzf@hotmail.com

## DL8983

Example 3: Apply ON/OFF flash/stop

Option key ,with external resistance.

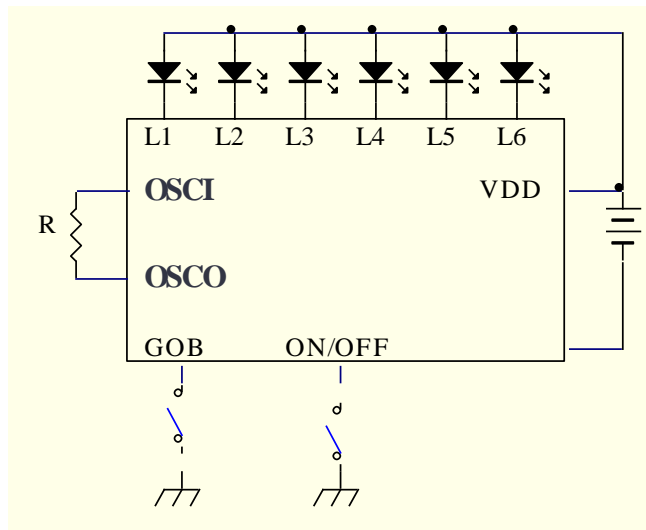

NOTE : 1:Please link ON/OFF pin to GND altering switches.

2:There are internal resistance.

3: You may alter flash frequency with external resistance.

4: Blink sequentially while OS pin is void ,and blink to and fro by bonding VSS.

Example 4: Apply OS key (trigger key)

without external resistance.

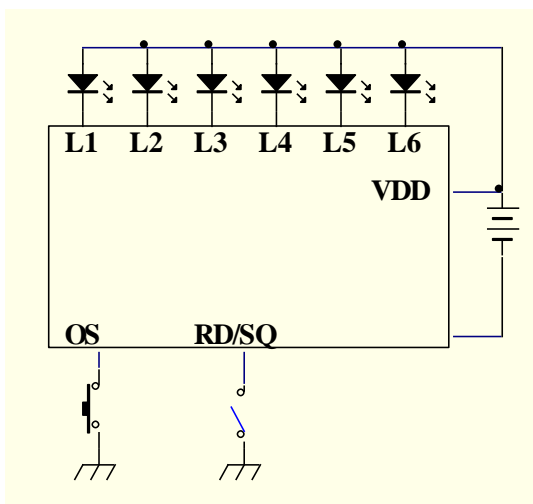

Example 5: Apply OS key (trigger key)

with external resistance.

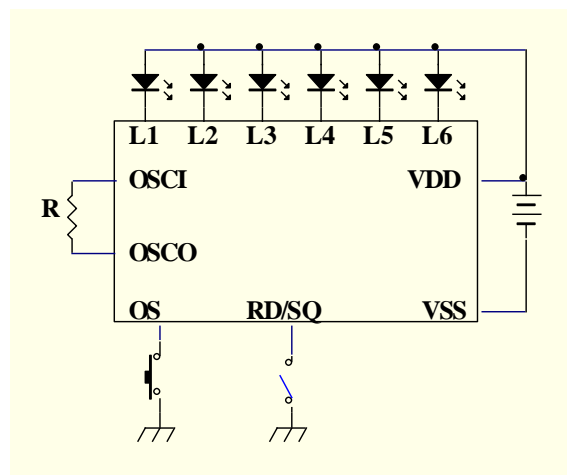



**DL8983**

Example 6: Apply flash key as all flash control .without external resistance.

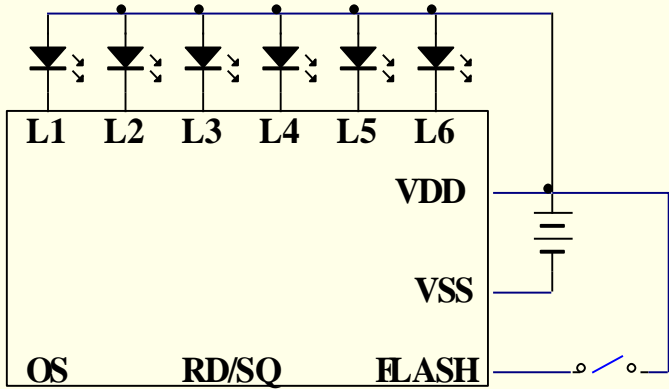

Example 7: Apply flash key as all flash control, with external resistance.

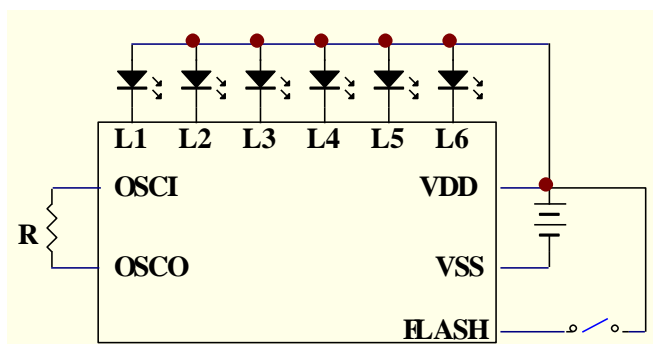

Example 8: Apply RST key as 4LED control without external resistance .

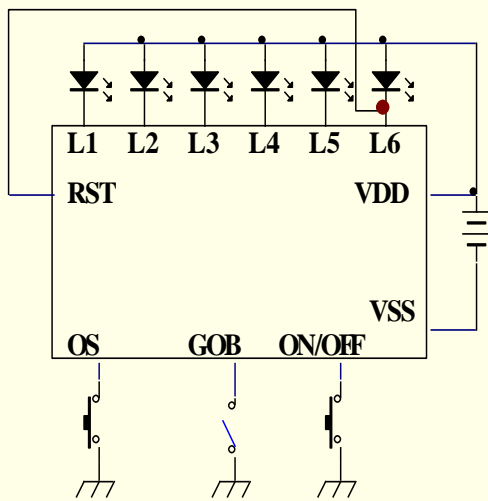

Example 9: Apply RST key as 4LED control with external resistance

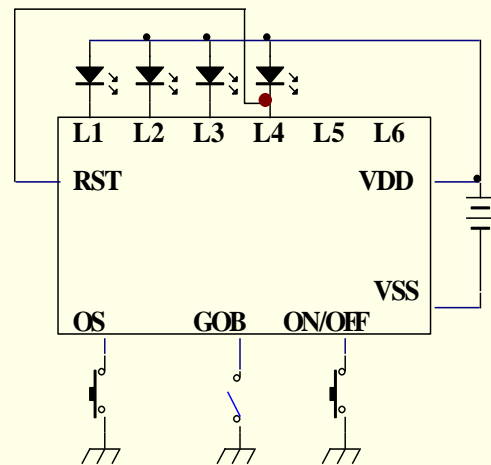

NOTE: Other control of light inferred in this way.

Example 10: Apply allow key as all flash control, external resistance.

