



深圳市晶峰达电子科技有限公司
东莞市琪芯电子有限公司

电话: 13798528768, 0755-29208918, FAX: 81703081
邮箱: info@jfd-ic.com, QQ: 402431824 阿里旺旺: szjfdz
网址: www.jfd-ic.com MSN: aleafuyzf@hotmail.com

DL5536(800mA)

800mA Adjustable & Fixed Voltage LDO Linear Regulator

General description

The DL5536 is a low-dropout linear regulator that operates in the input voltage range from +2.5V to +7.0V and delivers 800mA output current.

The DL5536 is available in two types, fixed output voltage type or adjustable output voltage type. The fixed output voltage type is preset at an internally trimmed voltage 1.8V, 2.5V, or 3.3V. Other options 1.5V, 2.85V, 3.0V and 3.6V are available by special order only. The output voltage range of the adjustable type is from 1.25V to 5V.

The DL5536 consists of a 1.25V bandgap reference, an error amplifier, and a P-channel pass transistor. Other features include short-circuit protection and thermal shutdown protection. The DL5536 devices are available in SOT-223 and TO-252 packages.

Features

- Low dropout voltage 700mV at 800mA typ.
- Adjustable output voltage (DL5536-Cx) or fixed output voltage (DL5536-xxCx) preset at 1.8V, 2.5V, or 3.3V
- High output voltage accuracy
- Fixed output voltage: $\pm 35\text{mV}$
- Adjustable output voltage: $\pm 50\text{mV}$
- Small output capacitor
- Output current limit
- Thermal overload shutdown protection
- SOT-223 and TO-252 packages

Applications

- Active SCSI terminators
- High efficiency linear regulators
- Monitor microprocessors
- Low voltage micro-controllers
- Post regulator for switching power



深圳市晶峰达电子科技有限公司

东莞市琪芯电子有限公司

电话:13798528768, 0755-29206918, FAX:81703081
邮箱:info@jfd-ic.com, QQ:402431824 阿里旺旺:szjfdz
网址:www.jfd-ic.com MSN:aleafuyzf@hotmail.com

DL5536(800mA)

800mA Adjustable & Fixed Voltage LDO Linear Regulator

Ordering information

DL5536(800mA)-XX X X

Package	Pin Out		
G:SOT-223	1. IN	2. GND	3. OUT
H:SOT-223	1. GND	2. IN	3. OUT
J:SOT-223	1. GND	2. OUT	3. IN
P:TO-252	1. IN	2. GND	3. OUT
R:TO-252	1. GND	2. OUT	3. IN

Note:For the adjustable voltage types, the GND pin is replaced with the ADJ pin

Temperature Range
 C:Commercial Standard
 P:Commercial Standard, Lead(Pb) Free and phosphorous(P) Free Package

Output Voltage
 (For fixed voltage types lnly.for adjustable voltage types,these two digits are eliminated.)
 15:1.5V 18:1.8V 25:2.5V
 29:2.85V 30:3.0V 33:3.3V
 36:3.6V
 Default: Adjustable Output
 Note:The output voltages other than the preset values are available by order only.

Pin configurations



800mA Adjustable & Fixed Voltage LDO Linear Regulator

Part No.	Pin1	Pin2	Pin3
DL5536-XXXG	IN	GND/ADJ (TAP)	OUT
DL5536-XXXH	GND/ADJ	IN (TAP)	OUT
DL5536-XXXJ	GND/ADJ	OUT (TAP)	IN

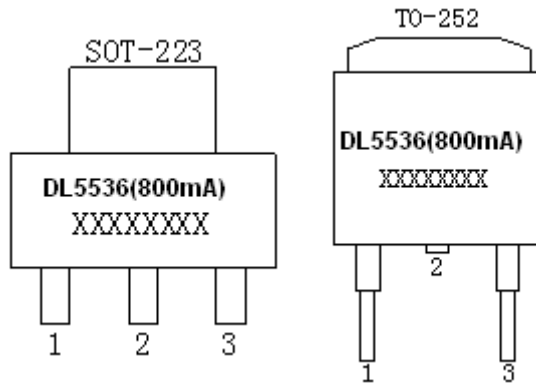

Part No.	Pin1	Pin2	Pin3
DL5536-XXXP	IN	GND/ADJ (TAP)	OUT
DL5536-XXXR	GND/ADJ	OUT (TAP)	IN

Package marking information

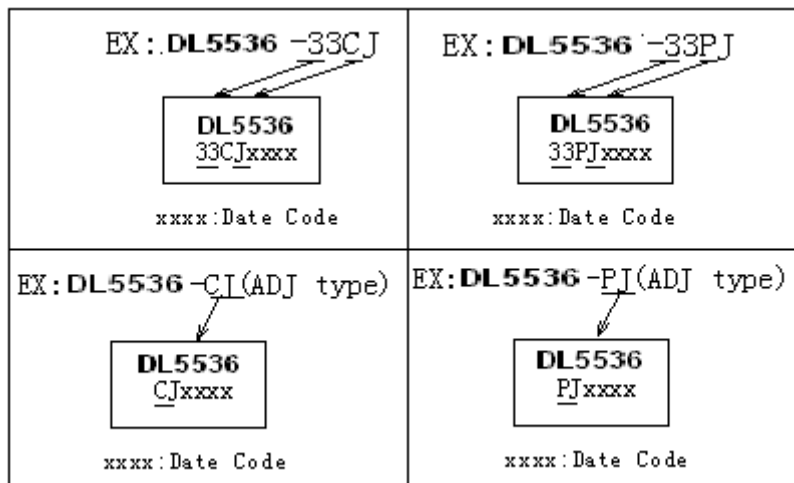



800mA Adjustable & Fixed Voltage LDO Linear Regulator

Pin description

Part No	Symbol	Description
DL5536-xxCG	GND/ADJ	Ground pin or adjust terminal pin
DL5536-xxCH	IN	Regulator input pin
DL5536-xxCJ	OUT	Regulator output pin
DL5536-xxCP		
DL5536-xxCR		

IN is the regulator input pin. Supply voltage can range from 2.5V to 7.0V. Bypass with a 10uF capacitor to GND.

OUT is the output voltage pin. Sources up to 800mA. Bypass with a 10uF capacitor to GND.

GND provides the reference for all voltages.

ADJ provides $V_{REF}=1.25V$ (TYP.) for adjustable output voltage.

Typical application circuit

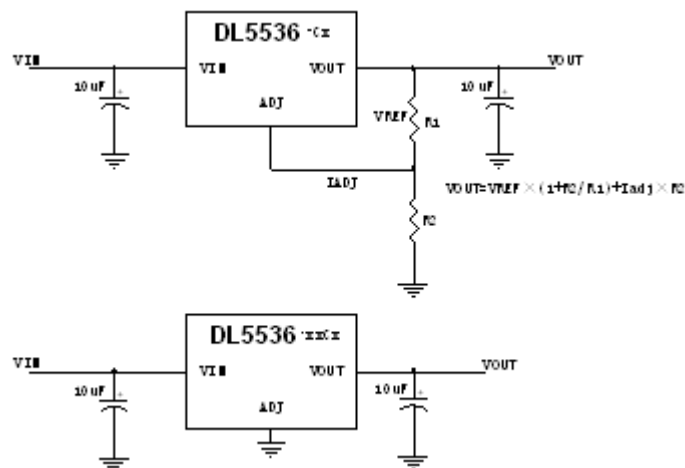

Functional block diagrams

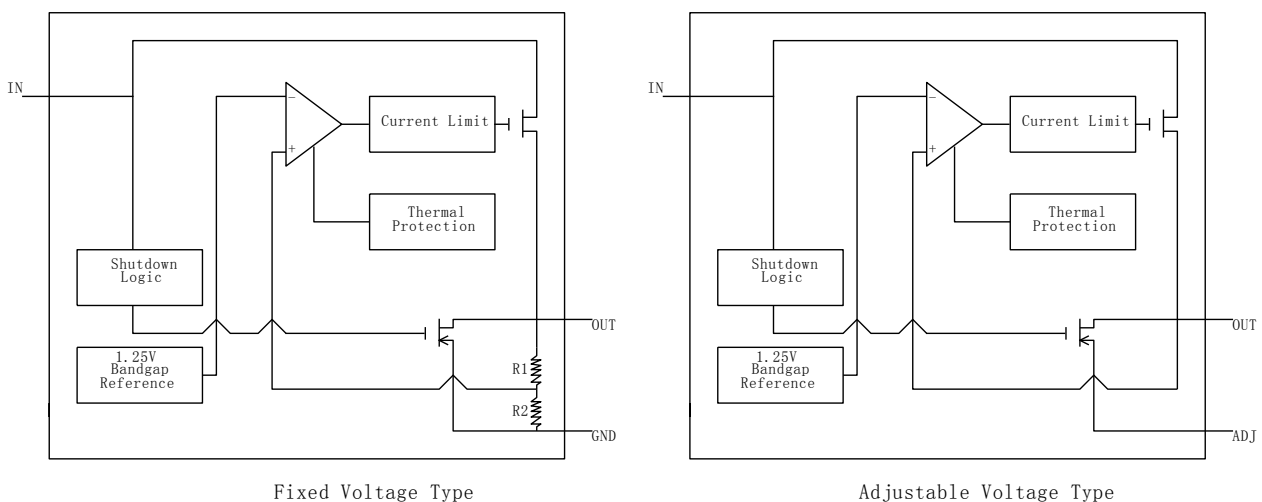



深圳市晶峰达电子科技有限公司
东莞市琪芯电子有限公司

电话: 13798528768, 0755-29208918, FAX: 81703081
邮箱: info@jfd-ic.com, QQ: 402431824 阿里旺旺: szjfdz
网址: www.jfd-ic.com MSN: aleafuyzf@hotmail.com

DL5536(800mA)

800mA Adjustable & Fixed Voltage LDO Linear Regulator

Absolute maximum ratings

Input voltage V_{IN} to GND-----	7V
Output current limit, I_{LIMIT} -----	800mA
Continuous power dissipation-----	Internally limited
Junction temperature, T_J -----	+155°C
Storage temperature range, T_{STG} -----	-55°C to +150°C
Operating junction temperature range-----	-40°C to +125°C
Lead temperature (soldering, 10sec)-----	260°C

* Stresses beyond those listed under “absolute maximum ratings” may cause permanent damage to the device. These are stress ratings only, and function operation of the device at these or any other conditions beyond those indicated under “recommended operating conditions” is not implied. Exposure to absolute-maximum-rated conditions for extended periods may affect device reliability.

Electrical characteristics($C_{IN}=10\mu F$, $C_{OUT}=10\mu F$, $T_A=25^\circ C$, unless otherwise noted.)

Symbol	Parameter	Test Conditions	Min	Typ	Max	Unit
V_{IN}	Input voltage		2.5		7.0	V
V_{OUT}	Output voltage	Fixed voltage type $V_{IN}=V_{OUT}+1.0V$, $I_{OUT}=1mA$	$V_{OUT}-$ 0.035	V_{OUT}	$V_{OUT}+$ 0.035	V
		Adjustable voltage type $V_{IN}=V_{OUT}+1.2V$, $I_{OUT}=1mA$	1.2	1.25	1.3	V
ΔV_{OUT}	Output voltage accuracy	$V_{IN}>V_{OUT}+1.0V$, $V_{IN}\leq 7V$ (fixed voltage type)	-35		+35	mV
		$V_{IN}>V_{OUT}+1.2V$, $V_{IN}\leq 7V$ (adjustable voltage type)	-50		+50	mV
I_{MAX}	Maximum output current		1.0			A
I_{LIMIT}	Current limit				1.3	A



深圳市晶峰达电子科技有限公司
东莞市琪芯电子有限公司

电话: 13798528768, 0755-29208918, FAX: 81703081
邮箱: info@jfd-ic.com, QQ: 402431824 阿里旺旺: szjfdz
网址: www.jfd-ic.com MSN: aleafuyzf@hotmail.com

DL5536(800mA)

800mA Adjustable & Fixed Voltage LDO Linear Regulator

I _{SC}	Short-circuit current	V _{OUT} =0V	V _{IN} >V _{OUT} +1.0V, (fixed voltage type)	650	760	mA
			V _{IN} >V _{OUT} +1.2V, (adjustable voltage type)			
I _Q	Ground pin current	I _{LOAD} =0mA to 1A, V _{IN} =V _{OUT} +1.0V		65	90	uA
I _{ADJ}	ADJ pin current	I _{LOAD} =0mA to 1A, V _{IN} =V _{OUT} +1.2V		65	90	uA
V _{DROP}	Dropout voltage (fixed output voltage version)	I _{OUT} =100mA		60	100	mV
		I _{OUT} =500mA		300	500	mV
		I _{OUT} =800mA		700	1000	mV
ΔV _{LINE}	Line regulation	V _{OUT} +1.0V<V _{IN} <7V, I _{LOAD} =1mA (fixed voltage type)		0.2	0.3	%/V
		V _{OUT} +1.2V<V _{IN} <7V, I _{LOAD} =1mA (adjustable voltage type)		0.2	0.3	%/V
ΔV _{LOAD}	Load regulation	I _{OUT} =0mA to 800mA (fixed voltage type)		0.02	0.03	%/mA
		I _{OUT} =0mA to 800mA (adjustable voltage type)		0.1	0.15	%/mA
EN	Output noise	F=1Hz to 10KHz, C _{OUT} =10uF		80		U/V _{RMS}
PSRR	Ripple rejection	F=10KHz, C _{OUT} =10uF		75		dB
T _{SD}	Thermal shutdown Temperature			155		°C
T _{HYS}	Thermal shutdown Hysteresis			20		°C
θ _{JA}	Thermal resistance(NO Heat-sink, No air flow)	SOT-223		155		°C/W
		TO-252		90		°C/W

Typical operating characteristics(C_{IN}=10uF, C_{OUT}=10uF, T_A= +25°C, unless otherwise noted.)

OUTPUT VOLTAGE vs. INPUT VOLTAGE

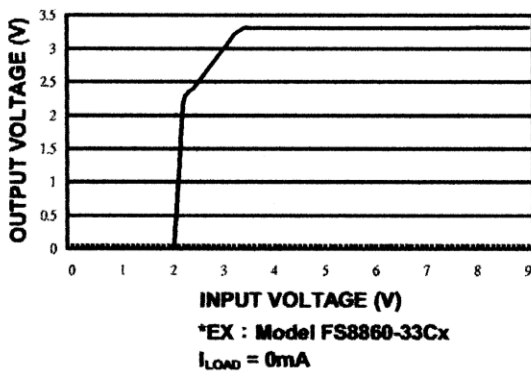

GROUND PIN CURRENT vs. AMBIENT TEMPERATURE

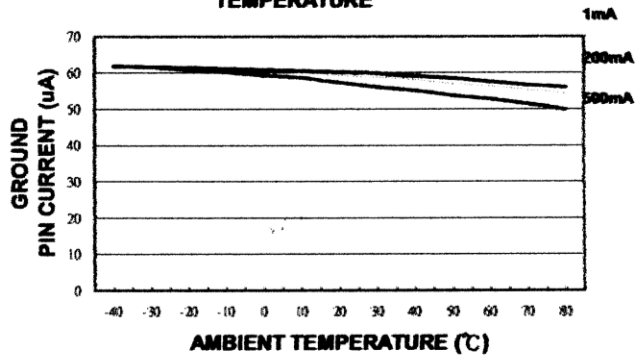

DROPOUT VOLTAGE vs. LOAD CURRENT

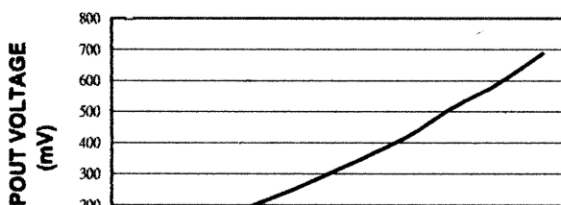

R_{on} vs. LOAD CURRENT

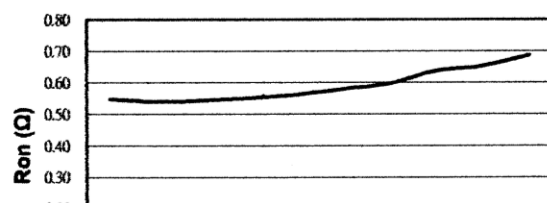



深圳市晶峰达电子科技有限公司

东莞市琪芯电子有限公司

电话: 13798528768, 0755-29208918, FAX: 81703081
邮箱: info@jfd-ic.com, QQ: 402431824 阿里旺旺: szjfdz
网址: www.jfd-ic.com MSN: aleafuyzf@hotmail.com

DL5536(800mA)

800mA Adjustable & Fixed Voltage LDO Linear Regulator

OUTPUT VOLTAGE vs. AMBIENT TEMPERATURE

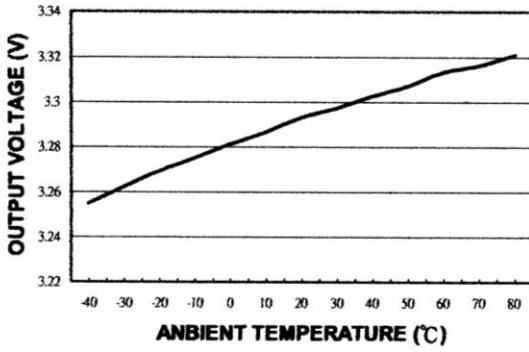

ADJ PIN CURRENT vs. INPUT VOLTAGE

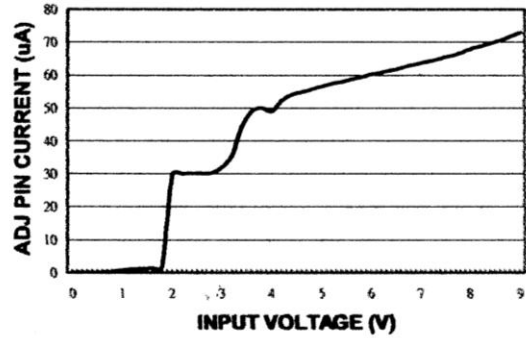

ADJ PIN CURRENT vs. LOAD CURRENT

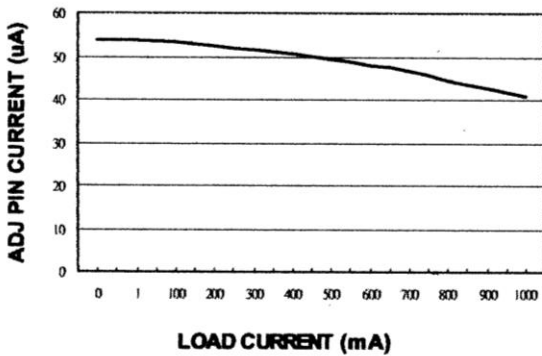

ADJ PIN CURRENT vs. AMBIENT TEMPERATURE

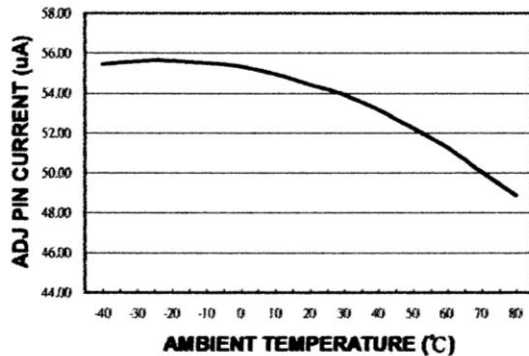

Vref vs. AMBIENT TEMPERATURE

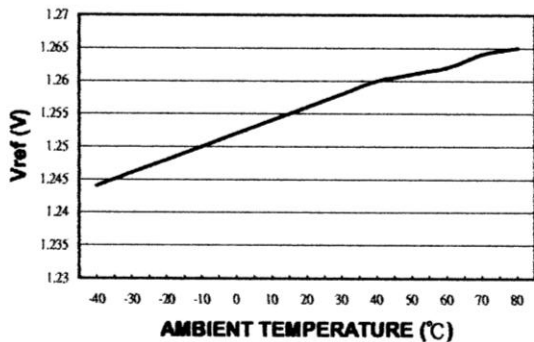

Output Noise DC to 1MHz

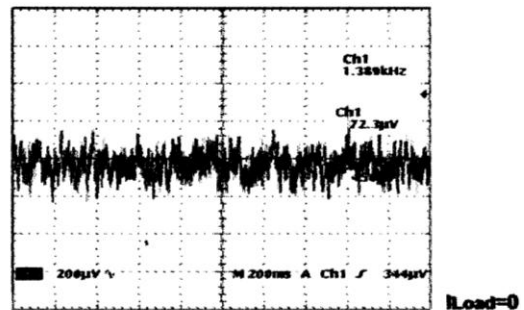



800mA Adjustable & Fixed Voltage LDO Linear Regulator

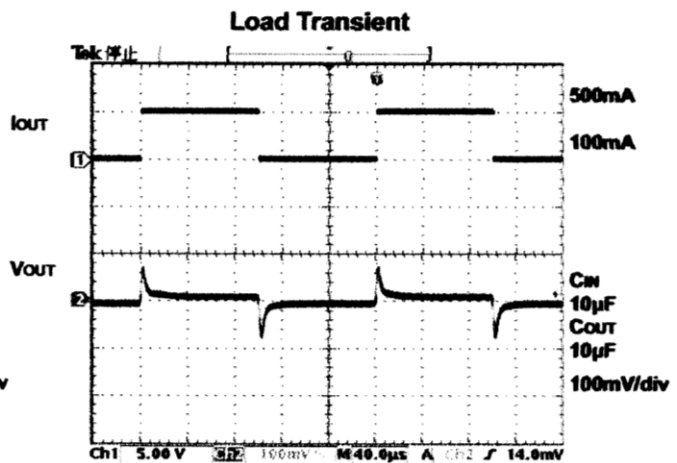
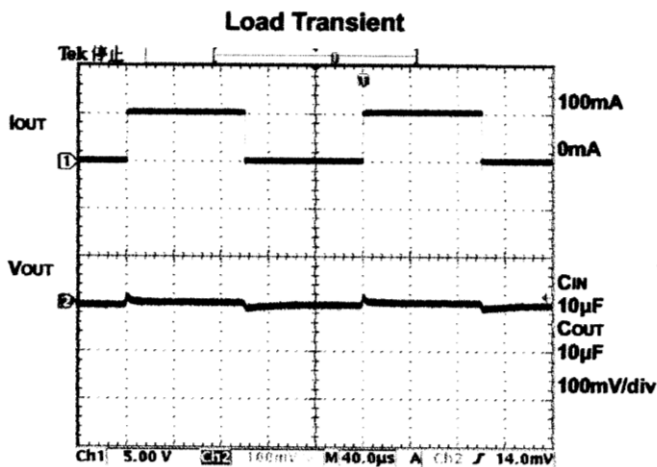
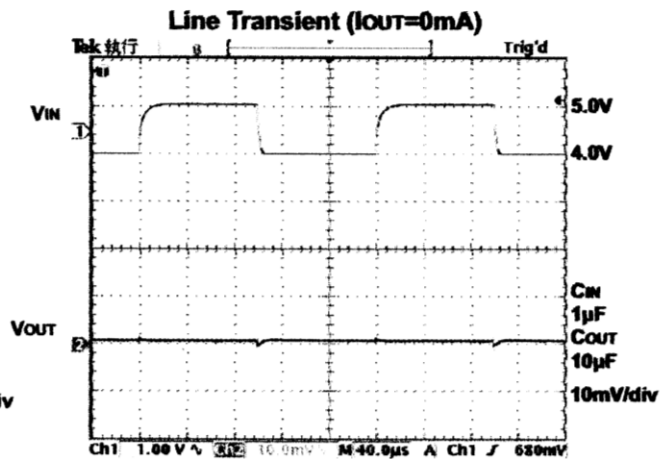
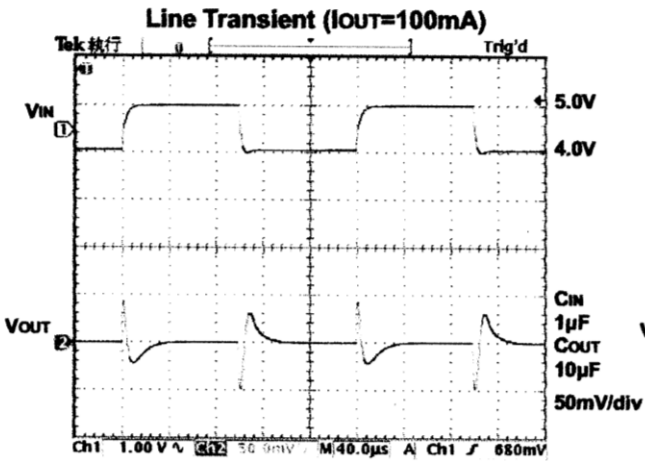
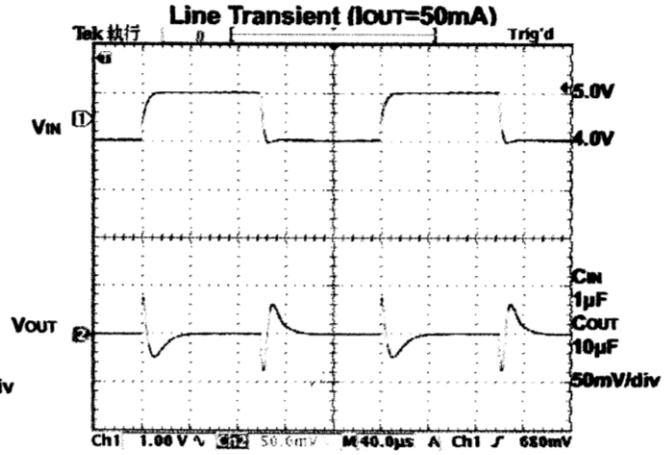
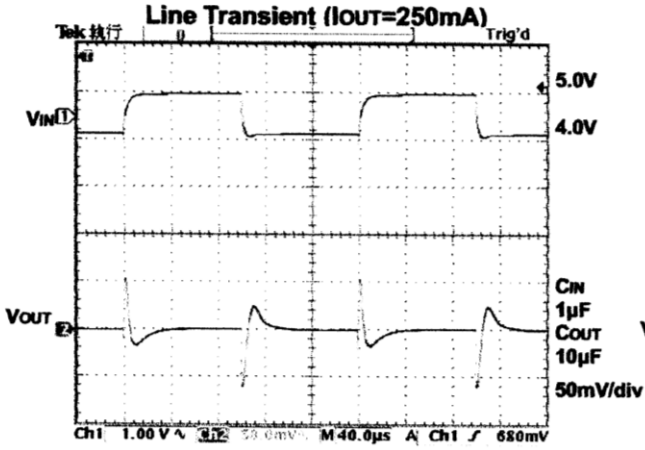



深圳市晶峰达电子科技有限公司
东莞市琪芯电子有限公司

电话: 13798528768, 0755-29206918, FAX: 81703081
邮箱: info@jfd-ic.com, QQ: 402431824 阿里旺旺: szjfdz
网址: www.jfd-ic.com MSN: aleafuyzf@hotmail.com

DL5536(800mA)

800mA Adjustable & Fixed Voltage LDO Linear Regulator

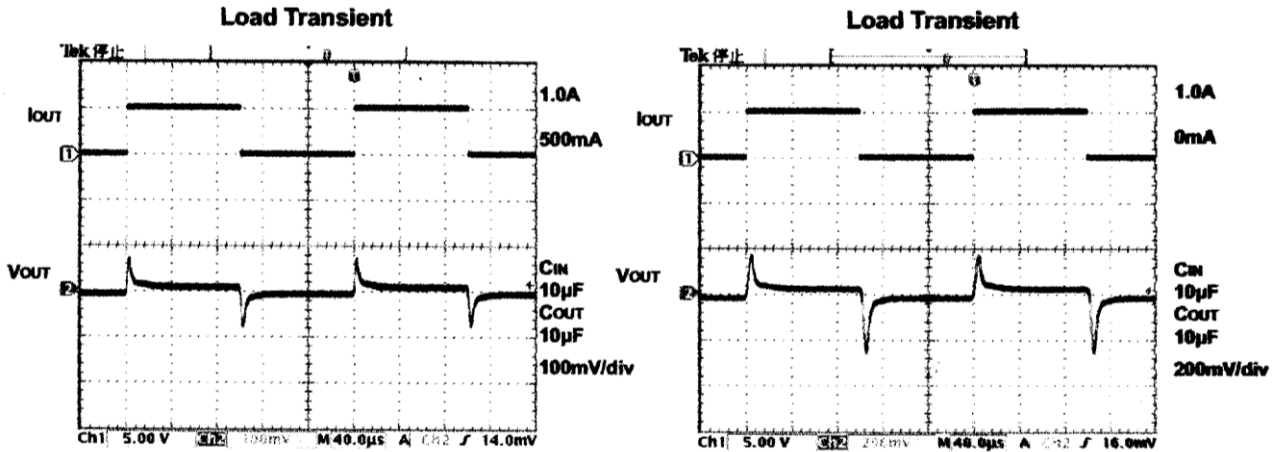

Detail description

The DL5536 is a low-dropout linear regulator. The device provides preset 1.8V, 2.5V and 3.3V output voltages for output current up to 800mA. adjustable output voltage and other mask options for special output voltages are also available. As illustrated in function block diagram, it consists of a 1.25V bandgap reference, an error amplifier, a P-channel pass transistor and an internal feedback voltage divider (fixed voltage types).

The 1.25V bandgap reference is connected to the error amplifier, which compares this reference with the feedback voltage and amplifies the voltage difference. If the feedback voltage is lower than the reference voltage, the pass-transistor gate is pulled lower, which allows more current to pass to the output pin and increases the output voltage. If the feedback voltage is too high, the pass-transistor gate is pulled up to decrease the output voltage.

The output voltage is feed back through an internal resistive divider (or external resistive divider for adjustable output voltage type) connected to OUT pin. Additional blocks include an output current limiter, thermal sensor, and shutdown logic.

Internal P-channel pass transistor

The DL5536 features a P-channel MOSFET pass transistor. Unlike similar designs using PNP pass transistors, P-channel MOSEFTS require no base drive, which reduces ground pin current. PNP-based regulators also waste considerable current in dropout when the pass transistor saturates, and use high base-drive currents under large loads. The DL5536 does not suffer from these problems and consumes only 65uA(Typ) of fround pin current under heavy loads as well as in dropout conditions.

Output voltage selection

For fixed voltage type of DL5536, the output voltage is preset at an internally trimmed voltage. The first two digits of part number suffix identify the output voltage (see [Ordering Information](#)). For example, the DL5536-33CJ has a preset 3.3V output voltage.

For adjustable voltage type of DL5536, the output voltage is set by comparing the feedback voltage at adjust terminal to the internal bandgap reference voltage. The reference voltage V_{REF} is 1.25V. The output voltage is given by the equation:

$$V_{OUT} = V_{REF} * (1 + R2/R1) + I_{ADJ} * R2$$

(see [Typical Application Schematic](#))

Current limit

The DL5536 also includes a fold back current limiter. It monitors and controls the pass transistor's gate voltage, estimates the output current, and limits the output current within 800mA.



800mA Adjustable & Fixed Voltage LDO Linear Regulator

Thermal overload protection

Thermal overload protection limits total power dissipation in the DL5536. When the junction temperature exceeds $T_J = +155^\circ\text{C}$, a thermal sensor turns off the pass transistor, allowing the IC to cool down. The thermal sensor turns the pass transistor on again after the junction temperature cools down by 20°C , resulting in a pulsed output during continuous thermal overload conditions.

Operating region and power dissipation

Maximum power dissipation of the DL5536 depends on the thermal resistance of the case and circuit board, the temperature difference between the die junction and ambient air, and the rate of airflow. The power dissipation across the device is $P = I_{OUT} \times (V_{IN} - V_{OUT})$. The resulting maximum power dissipation is:

$$P_{MAX} = (T_J - T_A) / (\theta_{JC} + \theta_{CA}) = (T_J - T_A) / \theta_{JA}$$

Where $(T_J - T_A)$ is the temperature difference between the DL5536 die junction and the surrounding air, θ_{JC} is the thermal resistance of the package chosen, and θ_{CA} is the thermal resistance through the printed circuit board, copper traces and other materials to the surrounding air. For better heat-sinking, the copper area should be equally shared between the IN, OUT, and GND pins.

If the DL5536 uses a SOT-223 package and this package is mounted on a double sided printed circuit board with two square inches of copper allocated for “heat spreading”, the resulting θ_{JA} is $80^\circ\text{C}/\text{W}$.

Based on the maximum operating junction temperature 125°C with an ambient of 25°C , the maximum power dissipation will be:

$$P_{MAX} = (T_J - T_A) / (\theta_{JC} + \theta_{CA}) = (125 - 25) / 80 = 1.25\text{W}$$

Thermal characteristics were measured using a double-sided board with $1'' \times 2''$ square inches of copper area connected to the GND pin for “heat spreading”.

Input-output voltage

A regulator’s minimum input-output voltage differential, or dropout voltage, determines the lowest usable supply voltage. In battery-powered systems, this will determine the useful end-of-life battery voltage. The DL5536 uses a P-channel MOSEFT pass transistor, its dropout voltage is a function of drain-to-source on-resistance ($R_{DS(ON)}$) multiplied by the output current.

$$V_{DROPOUT} = V_{IN} - V_{OUT} = R_{DS(ON)} \times I_{OUT}$$

Package outline

SOT-223

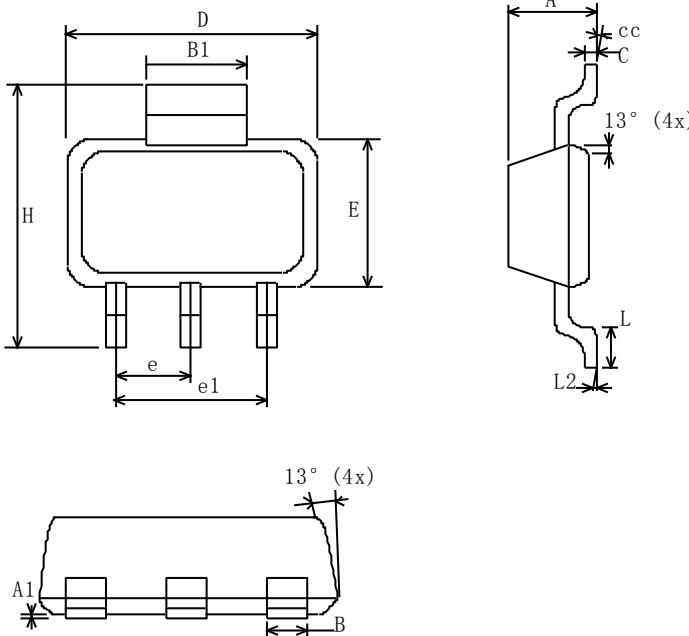

SYMBDLS	MILLIMETERS		DNCHES	
	MIN	MAX	MIN	MAX
A	1.55	1.90	0.061	0.071
A1	0.02	0.12	0.0008	0.0047
B	0.60	0.80	0.024	0.031
B1	2.90	3.10	0.114	0.122
C	0.24	0.32	0.009	0.013
D	6.20	6.70	0.248	0.264
E	3.30	3.70	0.120	0.146
e	2.30 BSC		0.090 BSC	
e1	4.60 BSC		0.181 BSC	
H	6.70	7.30	0.264	0.287

